

PRO APF Series IRELI 12" - LED (L)

Inset Runway Edge Light

Compliances:

- ICAO Annex 14: Fig. A2.8
- ICAO Annex 14: Fig. A2.9
- ICAO Annex 14: Fig. A2.10



Applications

The IREL/IRTEL is a high intensity bidirectional light. The IREL is used where taxiways intersect the runway and any other runway edge locations where it is impractical to use an elevated light. The IRTEL is used on runways where the threshold and end lighting are co-located and where it is impractical to use an elevated light.

Features

- Wavetrac™ technology reduces power consumption up to 60% compared to incandescent
- Dust and water tight to IP 68
- Modular design makes fixtures easy to maintain with fewer parts to stock
- Engineering Brief 67 current edition compliant dimming curve
- High frequency 400Hz PWM helps eliminate flicker perception
- 10kV/5kA surge protection
- 40C to +85C operating temperature ensures safe movement of aircraft in the most challenging locations
- Failure monitoring of fixtures
- Low Profile, < .25" (6.35mm) – FAA Style 3

Ordering Information

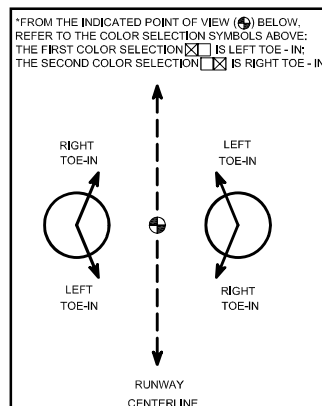
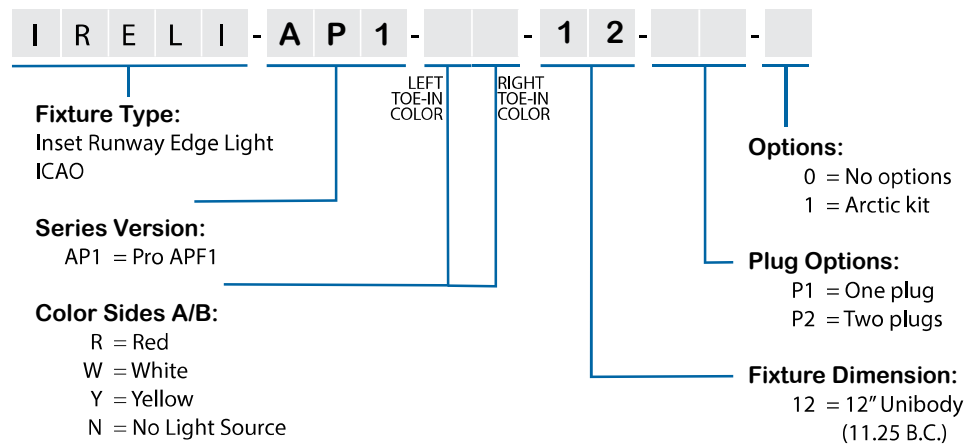

IREL Toe-in Details

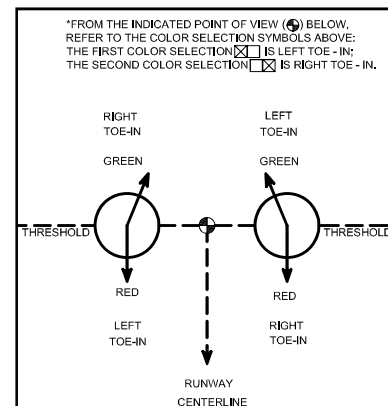

IRTEL Toe-in

Details Fixture Load and Isolation Transformer

Color	Power VA	Power VA (with Arctic Kit)	Transformer*	Transformer* (with Arctic Kit)	Power Factor at All Steps
WW	111	158	200W	200W	0.99
WY/YW	69	133	100W	200W	0.99
RY/YR	35	99	45W	100W	0.99
RR	26	90	20/25W	100W	0.99
WN/NW	47	79	65W	100W	0.99
YN/NY	22	54	20/25W	65W	0.99
RN/NR	13	45	20/25W	30/45W	0.99

*Transformer sold separately

Outline Drawings

Dimensions: Photo	See
Instruction Manual:	1231
Shipping Weight:	14.5 lbs., 6.58 kg.
Shipping Volume:	.33 cu. ft. .01 m ³

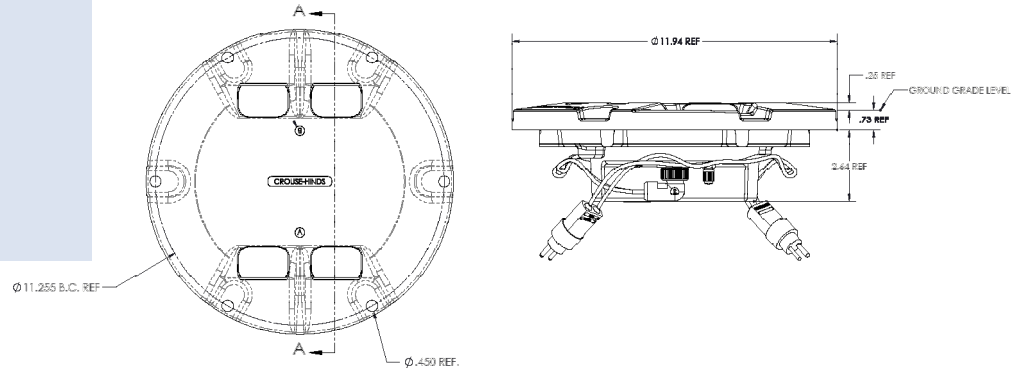

Photometric Data

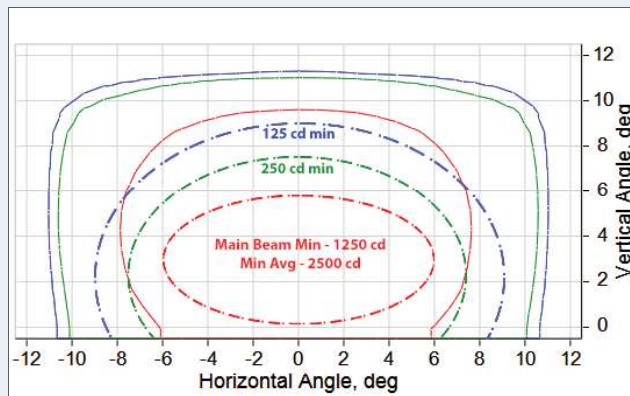

Fig 2-8 (Red)

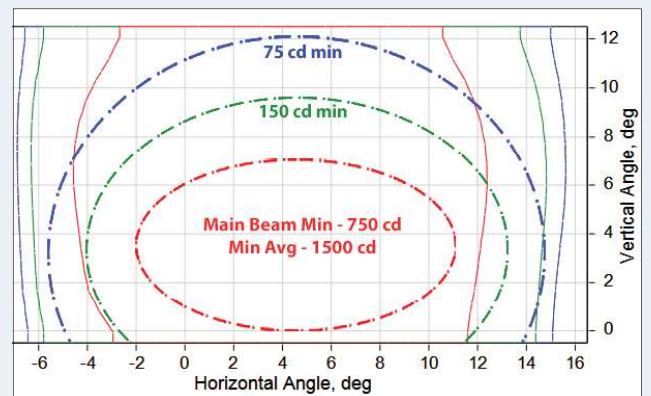

Fig 2-10 (Red)

Fig 2-10 (Yellow)

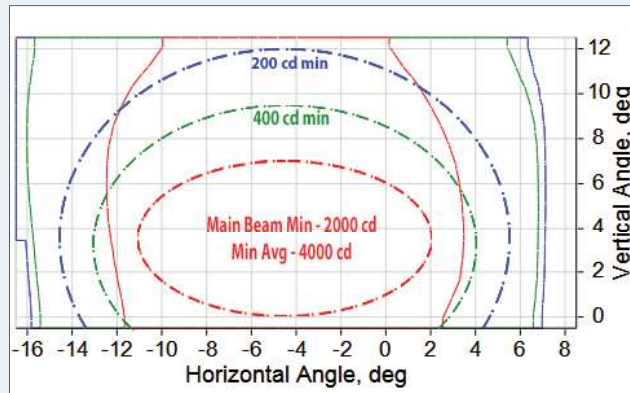
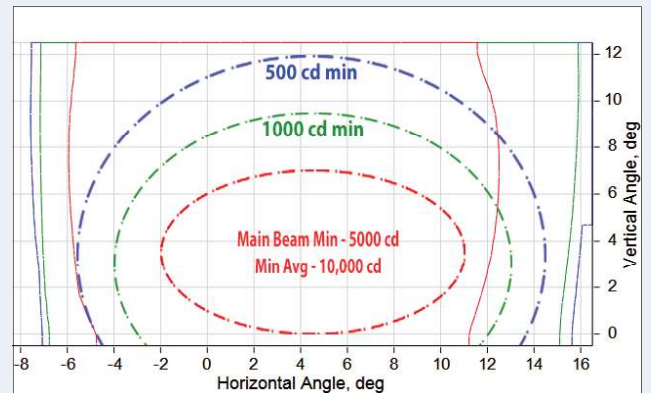

Fig 2-10 (White)



Accessories & Renewal Parts

Item Description	Catalog Number	Item Description	Catalog Number
Isolation Transformer	See Transformers Section	Arctic Lens Replacement Kit	21644-1-12
Connector Kit	54-D4-D4	Power Supply Replacement Kit	21645-1-12
Heat Shrink Kit - 1 Piece	10047-2154	Power Supply Replacement Kit with Arctic Kit Support	21645-2-12
Heat Shrink Kit - 2 Piece	10047-1425	Feed-through Assembly – 1 Lamp, 1 Connector	K3326992
Base L-868B Class I, 24" Deep	AC24242H200303	Gasket – Bottom Cover, Style III	21140
White Module Kit	21762-W	Lifting Tool	19999
Yellow Module Kit	21762-Y		
Red Module Kit	21762-R		